

Introduction

Ten years ago, the bandwidth of a state-of-the-art high-speed amplifier was 200MHz. With advancements in fabrication processes, current high-speed amplifiers have broken the GHz barrier. Savvy engineers look for more than speed in making their amplifier selections. The most defining characteristic of a high-speed amplifier is its feedback topology, using voltage feedback or current feedback. The strengths and limitations of each topology reveal its optimal uses.

The basic circuit topologies of voltage-feedback amplifiers (VFAs) and current-feedback amplifiers (CFAs) are presented here. The differences in topology are correlated to noise and distortion performance. Details about these performance limitations accompany typical values. Since both topologies will be presented in their bipolar implementation, a CMOS example is also included for a complete introduction into high-speed amplifier options.

Voltage-Feedback Amplifier (VFA) Topology

Voltage-feedback amplifiers are the most common operational amplifier topology. As most of us learned in college circuits classes, there are three stages: differential input stage, gain/level-shift stage, and output stage. Figure 1 presents a simplified schematic of the EL5157, a popular voltage-feedback amplifier.

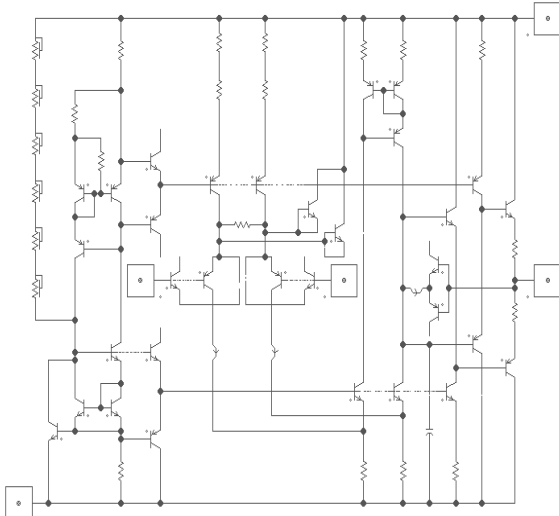

FIGURE 1. VFA CIRCUIT TOPOLOGY

The input stage is an NPN differential pair in parallel with a PNP pair. The second stage consists of a pull-up current

source. Note that any difference (signal or error) in the currents of the signal-path transistors appears across the output impedance of the current source at the high impedance node. The output stage buffers the high impedance node to the output.

Current-Feedback Amplifier (CFA) Topology

Current-feedback amplifiers have a very different input structure. In fact, the input stage has a unity gain buffer between its inverting and noninverting inputs. This gives the CFA topology some distinct advantages that will be discussed later. Their popularity lagged voltage-feedback designs until the emergence of the fully complementary bipolar process. Fortunately, these processes are widely available today, so CFAs can exploit the fact that current switching is faster than voltage switching in bipolar circuits (all other things being equal).

A simplified schematic is shown Figure 2. The non-inverting input is high impedance and is buffered to the inverting input (see dashed box). The input impedance of the inverting input is very low and its signal reaches the high impedance node through current mirrors. The high impedance node, Z, is buffered to the output.

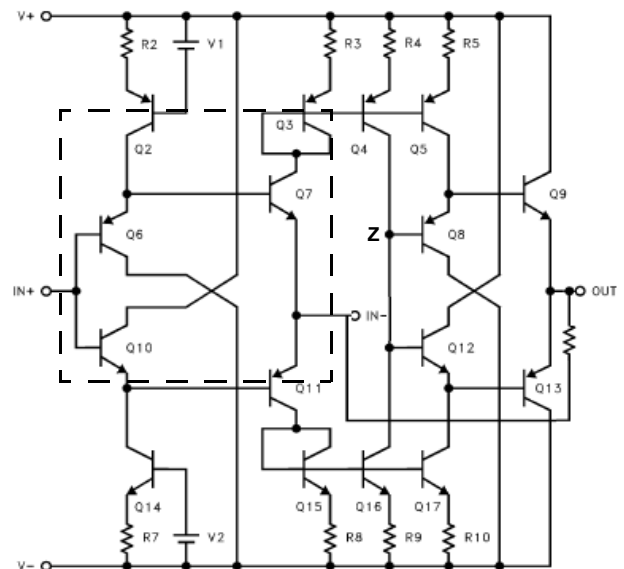

FIGURE 2. CFA CIRCUIT TOPOLOGY

A higher-level look at the CFA structure highlights its advantages, so a simplified model is presented in Figure 3. Any voltage difference across the feedback resistor (R_F) creates an error current into the inverting input. Since the impedance at the inverting input is low, this feedback is a current. A CFA is also called a transimpedance amplifier

because any change in the inverting input current results in a change of output voltage. It is noteworthy that the inverting input is capable of sourcing and sinking high transient currents, since it is not limited by a bias current. The current mirrors supply current on demand to the high impedance node from the power supply, giving CFAs high slew rates. A unity-gain buffer completes the circuit, driving the output to the voltage required to minimize the feedback error current.

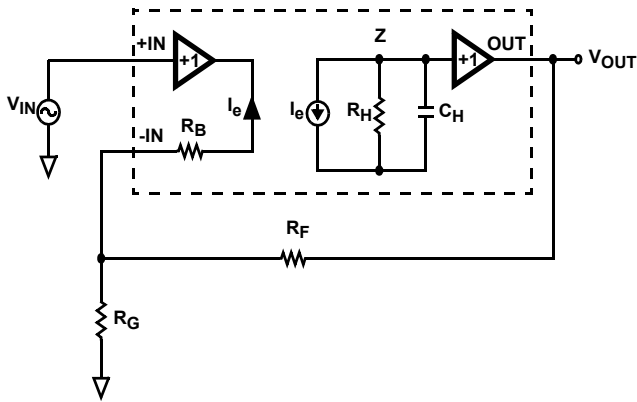

FIGURE 3. SIMPLIFIED CFA MODEL

The value of R_F determines the amount of current fed back to the inverting input. Therefore, when varying the gain of a CFA, it is suggested that the value of R_G be adjusted. Also, while VFAs exhibit a gain-bandwidth trade-off, CFA bandwidth is inversely proportional to the value of R_F .

Op Amp Noise Calculations

A classical noise model of an operational amplifier with feedback is presented in Figure 4. It shows all of the possible noise sources, including thermal noise (also called Johnson noise) voltages for the external feedback and gain resistors. While the resistor noise sources do not change versus frequency, the voltage and current noise sources in association with the op amp have frequency characteristics. Therefore, plots of input voltage and current noise are given in op amp datasheets.

The two main components of noise inside op amps are flicker noise and white noise. Flicker noise, also called 1/f noise because its contribution is inversely proportional to frequency, dominates at low frequencies (less than a few megahertz for CMOS and inside a few kilohertz for bipolar designs). White noise includes contributions of shot noise from bias currents and thermal noise from resistances in devices and other circuit structures. With its flat amplitude characteristic with respect to frequency, white noise dominates at medium and high frequencies. Table 1 lists the types of noises and their mathematical equivalents.

TABLE 1. DOMINANT TYPES OF NOISE IN AN OPERATIONAL AMPLIFIER

TYPE OF NOISE	CALCULATION
Thermal Noise (Johnson Noise)	$V_{JN} = \text{Sqrt}(4KT\Delta f)$
Shot Noise	$I_{SN} = \text{Sqrt}(2qI_{DC}\Delta f)$
Flicker Noise (1/f Noise)	$I_{FN} = \text{Sqrt}(k_d I_{DC}^a f^b \Delta f)$

where
 K = Boltzmann's constant (1.38×10^{-23} J/K)
 T = absolute temperature in Kelvin ($0^\circ\text{C} = 273$ Kelvin)
 R = resistance of component/device
 I_{DC} = DC current
 q = charge on an electron (1.6×10^{-19} C)
 Δf = system bandwidth
 f = center frequency of operation
 k_d = device constant (varies by orders of magnitude-even on one wafer, MOS tends to be higher than BJT)
 a = fabrication constant (ranges from 0.5-2)
 b = constant (approximately = 1)

By convention, noise quantities are input-referred. This means the value presented is the amount that would appear at the input to cause the resultant noise at the circuit output. For example, if a noise source exists at the output of an amplifier, it would be divided by the closed-loop gain to become input-referred. With all of the noise referred to the same node, the influence of various noise contributions can be compared and combined.

For the amplifier example in Figure 4, the noise sources can be calculated as shown in Table 2. To facilitate comparison, all noise sources have been presented in terms of voltage.

The third column identifies the voltage gain experienced by each noise source.

TABLE 2. AMOUNT OF NOISE PER NOISE SOURCE

NOISE SOURCE	NOISE (AS A VOLTAGE)	NOISE GAIN
Input Voltage Noise	V_n	$1 + R_F/R_G$
Inverting Input Current Noise	$I_{n-} * R_F$	1
Noninverting Input Current Noise	$I_{n+} * R_{ninv}$	$1 + R_F/R_G$
Johnson Noise of R_F	$\text{Sqrt}(4KT * R_F)$	1
Johnson Noise of R_G	$\text{Sqrt}(4KT * R_G)$	$- R_F/R_G$ (inverting)
Johnson Noise of R_{ninv}	$\text{Sqrt}(4KT * R_{ninv})$	$1 + R_F/R_G$

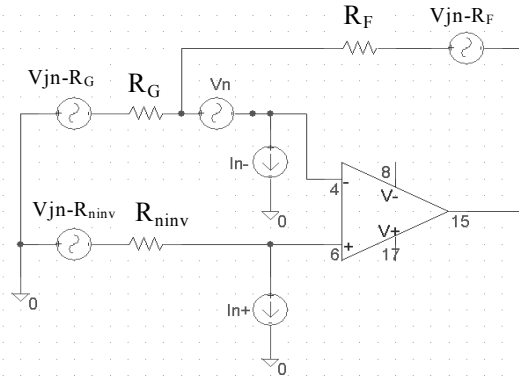

FIGURE 4. CLASSICAL NOISE MODEL OF OP AMP WITH FEEDBACK

Noise is a random quantity. The average voltage of a noise source is zero, just as the average voltage of a sine wave is zero. However, the average power is NOT zero. Therefore, when summing the contributions of different noise sources, we add the power of each noise contributor to get the total power. Power is proportional to voltage squared and inversely proportional to the impedance of that node:

$$P = I * V = (V/R) * V = V^2/R \quad \text{EQ.1}$$

With all of the noise sources referred to the same node, they will be across the same impedance. Therefore, we can calculate the total noise power at that point. If the related total voltage is desired, the answer lies in the reversal of Equation 1.

These noise sources in Table 2 are uncorrelated and can be summed as described in the preceding paragraphs. Correlated noise sources are generated by a single or dependent source, relating the behavior of one source to another. Since correlated noise sources have related noise behavior, the source powers cannot simply be added.

VFA and CFA Noise Analysis

To understand the noise differences between voltage-feedback and current-feedback amplifiers, one only needs to compare the architectural differences between their input stages (shown in Figure 1 and Figure 2.) The VFA input structure is a differential pair. Therefore, in bipolar technologies, the inputs are connected to bases of PNP and/or NPN transistor pairs. The currents through these nodes are small base currents, and since the noise current is proportional to the amount of base current, a low input noise current results.

The current-feedback amplifier, on the other hand, has two inputs connecting to very different structures. The noninverting op amp input connects to the base of bipolar transistors, so the noise current is comparable to the inputs of VFAs. Conversely, the inverting op amp input is the buffer's output, typically NPN and PNP emitters. Since

emitter current is much larger than base current (by a factor of beta), the noise is proportionally higher as well. CFA inverting input noise currents typically run in the 20-30pA/√Hz range, compared to the VFA's 1-5pA/√Hz typical range.

This larger noise current is transformed into a voltage through the feedback resistor, R_F. Input-referred noise voltage is a more complicated parameter, being a function of not only the input transistors (primarily transistor base resistance and collector current), but also the type of load driven by the input stage. For our general case, it is sufficient to say that CFAs typically deliver an input noise voltage that is at least on a par with VFAs that haven't been optimized for low noise. Table 3 shows typical noise currents and voltages for a voltage-feedback amplifier, a current-feedback amplifier, and a CMOS amplifier (for comparison).

TABLE 3. TYPICAL VALUES FOR NOISE QUANTITIES IN VFA, CFA AND CMOS TOPOLOGIES

	VFA	CFA	CMOS
Vn	0.86nV/√Hz	4nV/√Hz	20nV/√Hz
In-	1.4pA/√Hz	20pA/√Hz	2fA/√Hz
In+	1.4pA/√Hz	8pA/√Hz	2fA/√Hz

In a voltage-feedback amplifier, the circuit has been optimized for sensitivity to the voltage difference at the input. Therefore, the voltage noise contribution is the lowest of the three. The current noise at both inputs is low because the base current into each terminal is small.

For the current-feedback amplifier, the feedback node has emitter current flowing instead of a base current. This larger current will naturally have a larger current noise associated with it.

In the CMOS case, the input is purely capacitive. A simplified schematic is presented in Figure 5. The input is again a differential pair. Since both inputs connect to the gate of MOSFETs which allows virtually zero current flow, only the voltage determines the output signal. This explains the CMOS amplifier's low level of input current noise. The input voltage noise, while higher in the CMOS case, is still within an order of magnitude of the other two examples. So if the voltage gain is low, as in transimpedance amplifiers, then the higher level of noise is inconsequential. A drawback to CMOS amplifiers is that the 1/f knee frequency is inversely proportional to the device channel lengths, so the more advanced the process the higher the frequency of the 1/f knee.

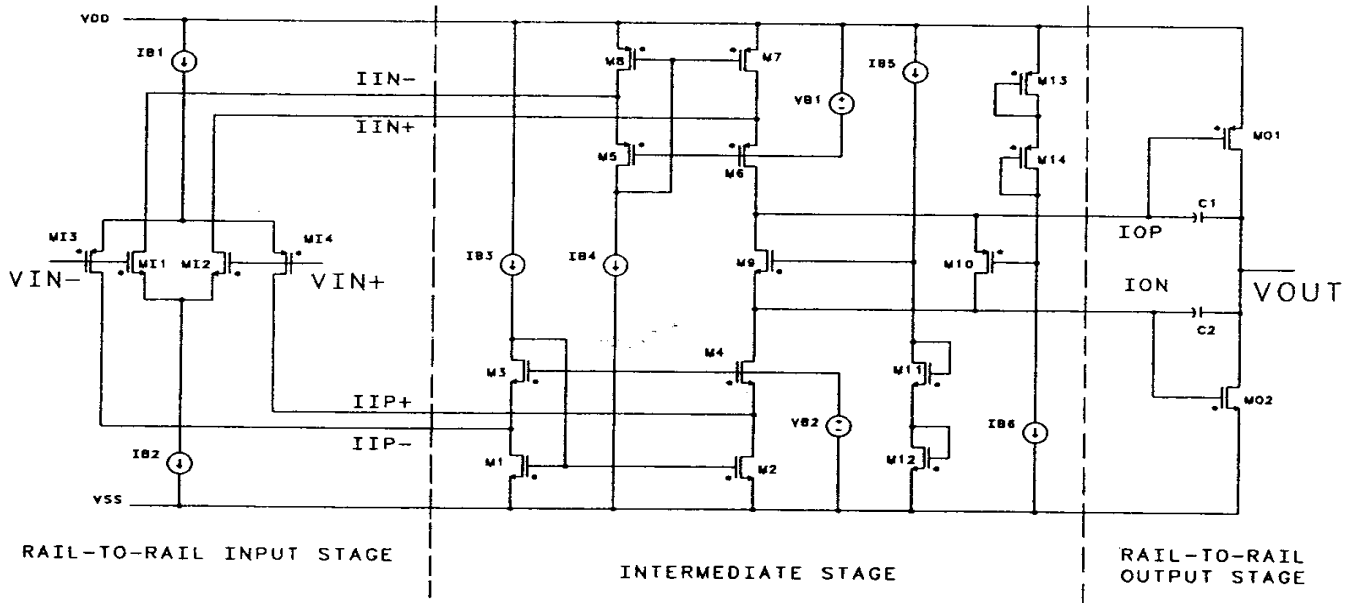

FIGURE 5. SIMPLIFIED CMOS OP AMP SCHEMATIC

VFA and CFA Distortion Characteristics

At low frequencies, voltage-feedback amplifiers provide the lowest distortion. The differential-pair input stage acts much like an electronic see-saw. When provided with negative feedback, the op amp attempts to level the see-saw. Distortion values from the datasheets of typical CFA and VFA amplifiers are provided in Figures 6A and 6B. Of course, there are products on the market that do not follow these curves. Check the datasheet before choosing an amplifier for your application.

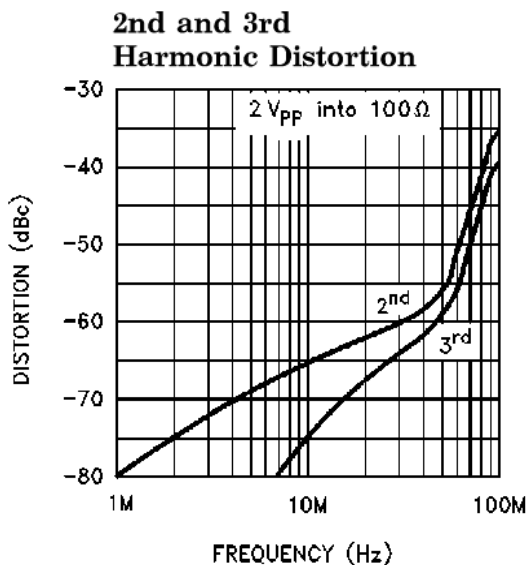

FIGURE 6A. EL2070 CFA DISTORTION COMPARISON

2nd and 3rd Harmonic Distortion vs Frequency

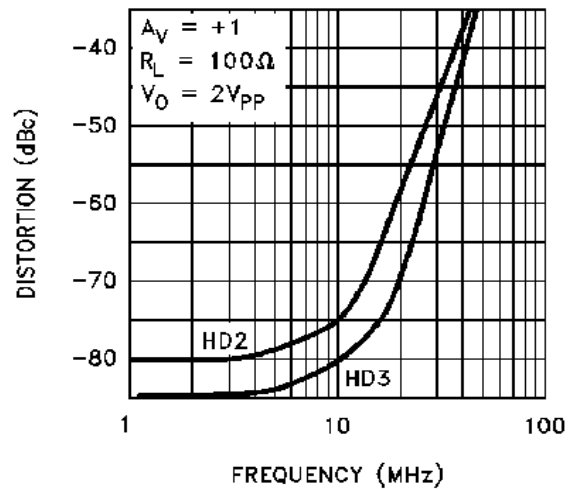

FIGURE 6B. EL2073 VFA DISTORTION COMPARISON

The current-feedback amplifier accepts a voltage at the noninverting input and a current at the inverting input. The see-saw effect is still there, but only after V_{in+} is translated into a current. This translation is imperfect, introducing errors which appear in the 2nd harmonic distortion. At higher frequencies, the majority of loss comes from slew rate limitations. Since CFAs have higher slew rate than VFAs, they exhibit lower distortion characteristics at high frequencies. Also note that current feedback amplifiers give relatively constant distortion results for different gain settings.

Voltage-Feedback Example Application- xDSL Line Driver and Receiver

In xDSL systems, communication signals are transmitted through telephone lines that can reach lengths of 20,000 feet. The receiving signal can be as low as 30mV with a 4MHz bandwidth. A low noise amplifier is required to amplify the receive signal. The signal must also be filtered to remove the high frequency noise from the lower frequency transmit signal.

The closed-loop gain of the line receiver is at least 30V/V and the analog-to-digital converter of the driver front end has 14-bit resolution. To fully utilize the full range of the 14-bit ADC, the signal-to-noise ratio of the input must be greater than 84.3dB. For example, a 20mV input signal would require a noise level under 1.2mV. The limit of the amplifier's input voltage noise is then $0.9nV/\sqrt{Hz}$ with a 4MHz bandwidth. A voltage feedback amplifier is preferred-not only for its low input voltage noise, but also for the fact that VFA's are more flexible in active filter configurations.

Current-Feedback Example Application- Driving an ADC

An application where CFAs excel is driving high speed, high resolution ADCs, especially for pulsed inputs. A distinct CFA advantage for this application is that the CFA's output rise time remains nearly constant, regardless of the output step size. The slewing current is equivalent to the inverting input current during transients, which is a function of the voltage difference across R_F . Therefore the CFA's slew rate actually increases as the step size increases. Whereas a VFA may become slew-rate limited for voltage swings less than 1V, CFAs typically do not reach slew-rate limit for steps less than several volts.

In addition to the CFA's slew-rate advantage, its exceptional bandwidth (be careful, because excess BW still contributes to total noise), distortion, settling time, and relatively low supply current make it a prime contender for ADC drivers. For example, the EL5166 is an excellent choice for driving 14 bit ADCs, due to its 1.4GHz bandwidth, 6000V/ μs slew rate, and 70dB second harmonic distortion at 20MHz. With ADC drivers, the load presented by the CFA's feedback network is not usually a concern. This allows the designer to utilize low resistance feedback resistors to minimize noise contribution, while maximizing the CFA's performance.

CMOS Example Application- Transimpedance Amplifier/Photodetector

Wide bandwidth and low input bias and noise currents make modern high-speed CMOS amplifiers ideal choices for photodiode transimpedance amplifiers. The key elements in a transimpedance design, as shown in Figure 7, are capacitance at the inverting input (including diode capacitance, input capacitance from the amplifier, and parasitic capacitance), the transimpedance gain set by R_F ,

low input current noise to allow wide dynamic range, and sufficient Gain-Bandwidth. With these three variables set, a feedback capacitor in parallel with R_F is often needed to control the frequency response and ensure stability.

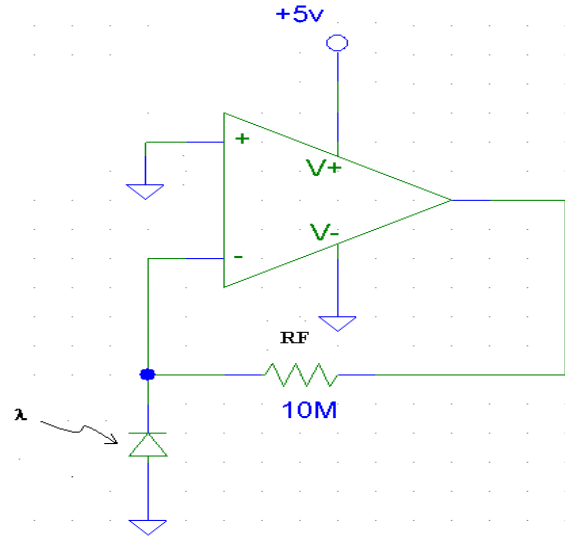

FIGURE 7. TRANSIMPEDANCE AMPLIFIER CIRCUIT

If the amplifier is a rail-to-rail, single-supply device, the noninverting input can be connected to ground, allowing the output to reach true zero when the photodiode is not exposed to any light. This allows the circuit to avoid the delay the output would need to travel from the negative rail.

To achieve the best performance, components should be selected according to the following guidelines:

1. For lowest overall system noise, select R_F to provide all the required gain in the transimpedance stage. Since the CMOS amp has virtually no current noise, a lower value of R_F (to lower the noise of the transimpedance stage), would necessitate including additional gain stages, ultimately producing poorer overall noise performance. The noise produced by R_F increases as the square root of resistance, whereas the signal value increases linearly, therefore, signal-to-noise ratio is improved when all of the required gain is placed in the transimpedance stage.
2. Minimize capacitance at the inverting input. This capacitance causes the voltage noise of the op amp to be amplified. A low-noise voltage source to reverse-bias a photodiode can significantly reduce its capacitance. Smaller photodiodes have lower capacitance. Use optics to concentrate light on a small photodiode.
3. Limit the circuit bandwidth to only that required, since noise increases with increased bandwidth. Use a capacitor across the feedback resistor to limit bandwidth, even if not required for stability.
4. Circuit board leakage can degrade the performance of an otherwise well-designed amplifier. Clean the circuit board carefully. A circuit board guard trace that encircles the summing junction (inverting input) and is driven at the same voltage can help control leakage.

Conclusion

Both current- and voltage-feedback amplifier topologies are popular choices for high-speed applications. An understanding of the differences in circuit topology along with basic noise and distortion characteristics are crucial for optimal product selection. Table 4 summarizes the discussion and examples presented.

TABLE 4. SUMMARY OF OP AMP TOPOLOGIES, STRENGTHS, AND APPLICATIONS

TOPOLOGY	STRENGTHS	EXAMPLE USE
VFA	Input Symmetry Low Input Voltage and Current Noise Low Distortion @ Low Frequency	Communications Systems
CFA	Slew Rate Bandwidth Low Distortion @ High Frequency	ADC Driver
CMOS	Dynamic Range Rail-to-Rail Operation Lowest Input Current Noise	Transimpedance Amplifier/ Photodetector

All Intersil U.S. products are manufactured, assembled and tested utilizing ISO9000 quality systems. Intersil Corporation's quality certifications can be viewed at www.intersil.com/design/quality

Intersil products are sold by description only. Intersil Corporation reserves the right to make changes in circuit design, software and/or specifications at any time without notice. Accordingly, the reader is cautioned to verify that data sheets are current before placing orders. Information furnished by Intersil is believed to be accurate and reliable. However, no responsibility is assumed by Intersil or its subsidiaries for its use; nor for any infringements of patents or other rights of third parties which may result from its use. No license is granted by implication or otherwise under any patent or patent rights of Intersil or its subsidiaries.

For information regarding Intersil Corporation and its products, see www.intersil.com