

DC VOLUME, TONE CONTROL CIRCUIT

The KA2107 is a monolithic integrated circuit designed for 2 channel volume and tone control.

FUNCTIONS

- DC Volume Control
- DC Tone Control (Bass & Treble)
- Balance Control (R, L-Ch)

12-SIP

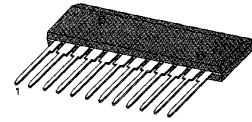

ORDERING INFORMATION

Device	Package	Operating Temperature
KA2107	12-SIP	-20°C ~+70°C

FEATURES ORDERING INFORMATION

- Easier compact set design
- All function enable DC controllable

BLOCK DIAGRAM

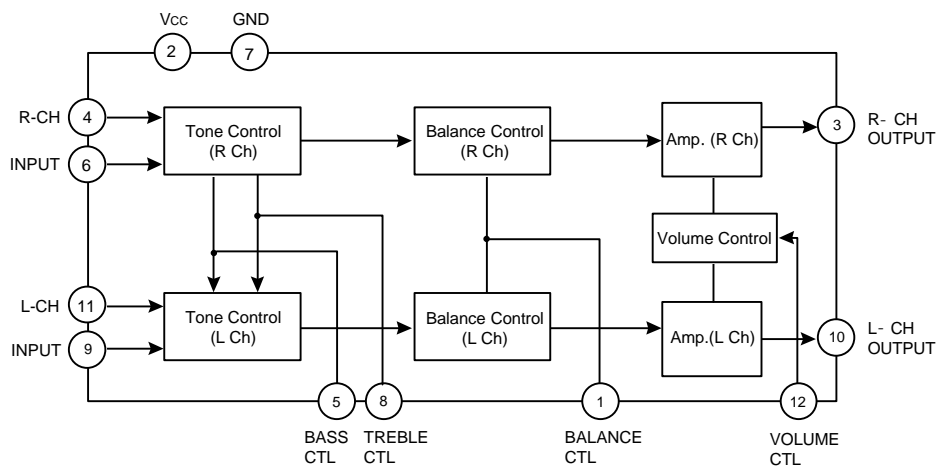

Fig. 1

ABSOLUTE MAXIMUM RATINGS ($T_A = 25^\circ\text{C}$)

Characteristic		Symbol	Value		Unit
Voltage	Supply Voltage	V_{CC}	14.4		V
	Circuit Voltage	$V_{1,4,5,6-7}$ $V_{8,9,11,12-7}$	0	V_{2-7}	V
Current	Supply Current	I_2	64		mA
	Circuit Current	I_3, I_{10}	-40	-	mA
Power Dissipation		P_D	920		mW
Temperature	Operating Temperature	T_{OPR}	-20~+70		$^\circ\text{C}$
	Storage Temperature	T_{STG}	-55~+150		$^\circ\text{C}$

ELECTRICAL CHARACTERISTICS ($V_{CC}=12\text{V}$, $T_A = 25^\circ\text{C}$)

Characteristic		Symbol	Condition	Min	Typ	Max	Unit	Test Circuit
Supply Current		I_{TOT}	$V_{CC}=12\text{V}$	24	38	50	mA	1
Supply Voltage		$V_{3, 10-7}$	No input, $V_{12}=V_{CC}$, $V_1=V_5=V_8=V_{CC}/2$	8.0	8.4	8.8	V	2
Volume	Max Output Voltage	V_{OMAX}	$f=1\text{KHz}$, $V_1=400\text{mVms}$	190	230	270	mVms	2
	Channel Balance	CB	$V_{12}=V_{CC}$, $V_1=V_5=V_8=V_{CC}/2$	-	+0.2	± 1.0	dB	2
	Output Starting Voltage	$V_{(ST)}$	$f=1\text{KHz}$, $V_1=400\text{mVms}$ $V_{12}=V_R$, $V_1=V_5=V_8=V_{CC}/2$	0.40	0.65	0.90	V	2
	Residual Noise Level	V_{MIN}	$f=1\text{KHz}$, $V_1=400\text{mVms}$ $V_{12}=0\text{V}$, $V_1=V_5=V_8=V_{CC}/2$	-	25	50	μVms	2
Balance	Attenuation (R-Ch)	ATT_R	$f=1\text{KHz}$, $V_1=400\text{mVms}$, $V_{12}=V_{CC}$, $V_5=V_8=V_{CC}/2$, V_{OR} , $V_1=(5.5/12) \cdot V_{CC}$ (at VR.1), V_{OR2} , $V_1=0\text{V}$	-32	-45	-	dB	2
	Attenuation (L-Ch)	ATT_L	$f=1\text{KHz}$, $V_1=400\text{mVms}$, $V_{12}=V_{CC}$, $V_5=V_8=V_{CC}/2$, V_{OL1} , $V_1=(6.5/12) \cdot V_{CC}$ (at VR.1), V_{OL2} , $V_1=V_{CC}$	-32	-45	-	dB	2
Tone	Low Frequency Boost Control	V_{40}/V_{1K}	V_{1K} : Output Voltage at $f=1\text{KHz}$, $V_1=400\text{mVms}$ $V_{12}=V_{CC}$, $V_1=V_5=V_8=V_{CC}/2$ V_{40} : Output Voltage at $f=40\text{Hz}$, $V_1=40\text{mVms}$ $V_{12}=V_{CC}$, $V_5=V_8=V_{CC}$	8	10	12	dB	2
	Low Frequency Cut Control	V_{40}/V_{1K}	V_{1K} : Output Voltage at $f=1\text{KHz}$, $V_1=400\text{mVms}$ $V_{12}=V_{CC}$, $V_1=V_5=V_8=V_{CC}/2$ V_{40} : Output Voltage at $f=40\text{Hz}$, $V_1=40\text{mVms}$ $V_{12}=V_{CC}$, $V_5=V_8=0\text{V}$	-7.5	-12	-16	dB	2
	High Frequency Boost Control	V_{15K}/V_{1K}	V_{1K} : Output Voltage at $f=1\text{KHz}$, $V_1=400\text{mVms}$ $V_{12}=V_{CC}$, $V_1=V_5=V_8=V_{CC}/2$ V_{15K} : Output Voltage at $f=15\text{KHz}$, $V_1=40\text{mVms}$ $V_{12}=V_{CC}$, $V_5=V_8=V_{CC}$	7.5	10	13	dB	2
	High Frequency Cut Control	V_{15K}/V_{1K}	V_{1K} : Output Voltage at $f=1\text{KHz}$, $V_1=400\text{mVms}$ $V_{12}=V_{CC}$, $V_1=V_5=V_8=V_{CC}/2$ V_{15K} : Output Voltage at $f=40\text{Hz}$, $V_1=40\text{mVms}$ $V_{12}=V_{CC}$, $V_5=V_8=0\text{V}$	-7.5	-12	-18	dB	2

ELECTRICAL CHARACTERISTICS (Continued)

Characteristic	Symbol	Condition	Min	Typ	Max	Unit	Test Circuit
Cross Talk	CT	$f = 1\text{KHz}$, $V_1 = 400\text{mV}_{\text{rms}}$ $V_{12} = V_{CC}$, $V_1 = V_5 = V_8 = V_{CC}/2$	-65	-80	-	dB	2
Output Noise Voltage	V_{NO}	No input, $V_{12} = V_{CC}$, $V_1 = V_5 = V_8 = V_{CC}/2$	-	80	120	μV_{rms}	2
Total Harmonic Distortion	THD	$f = 1\text{KHz}$, $V_1 = 400\text{mV}_{\text{rms}}$ $V_{12} = V_{CC}$, $V_1 = V_5 = V_8 = V_{CC}/2$	-	0.2	0.5	%	2
Input Resistance	$R_{1(6),(9)}$	$f = 1\text{KHz}$	8.2	11.0	13.5	$\text{K}\Omega$	
	$R_{1(4),(11)}$		11.0	16.0	22.0	$\text{K}\Omega$	
Output Resistance	$R_{O(3),(10)}$	$f = 1\text{KHz}$	60	110	160	Ω	

TEST CIRCUIT

Test Circuit 1 (I_{tot})

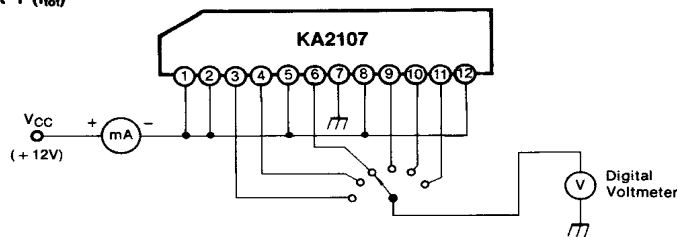

Test Circuit 2 (V_3 , 10-7, V_{OMAX} , CB, V_{ST} , V_{MIN} , ATT_R, ATT_L, V_{40}/V_{1K} , V_{15K}/V_{1K} , CT, V_{NO} , THD)

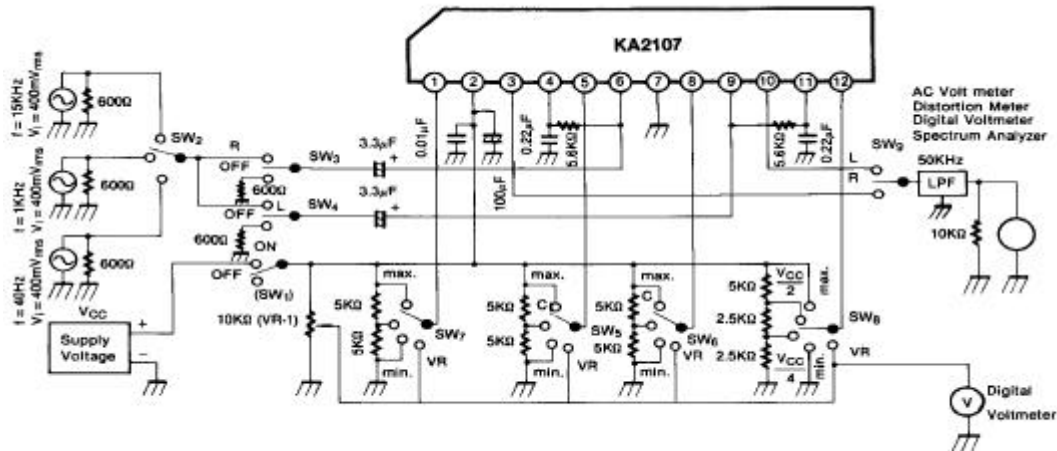

- Switch
- (SW₁) ... Supply Voltage
 - (SW₂) ... Input Signal
 - (SW₃) ... R Side Input
 - (SW₄) ... L Side Input
 - (SW₅) ... Bass Control
 - (SW₆) ... Treble Control
 - (SW₇) ... Balance Control
 - (SW₈) ... Volume Control
 - (SW₉) ... Output Control

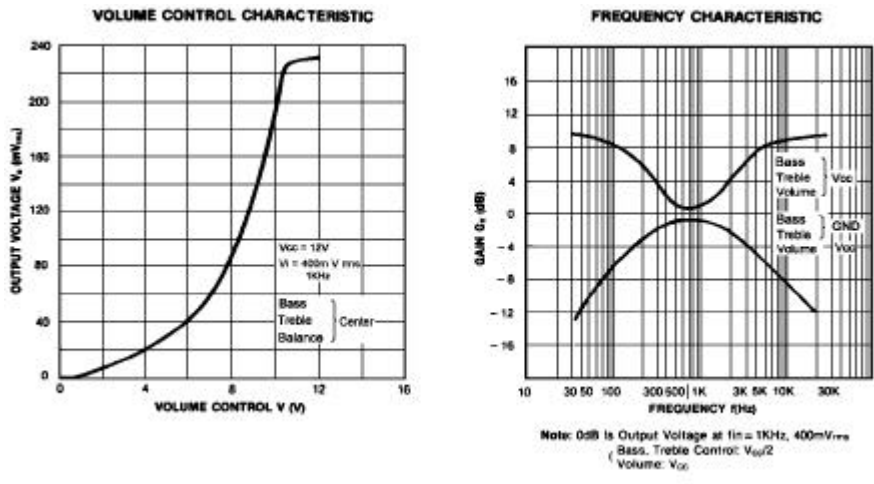

TYPICAL APPLICATION CIRCUIT

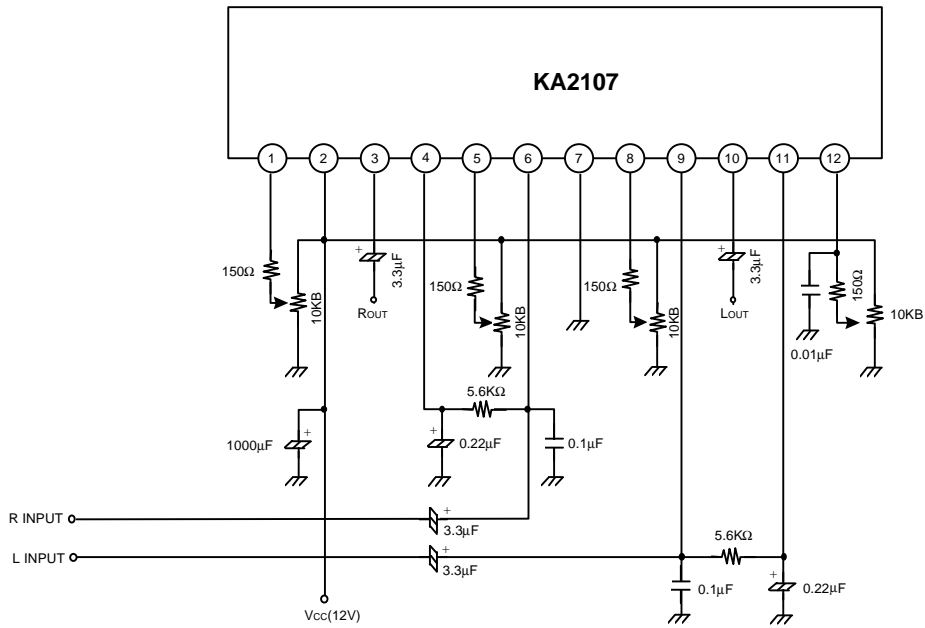

Fig. 3